

INSTALLATION OF HYDRAULIC SHAFT SEAL KIT 990709.

Units Having Lip Seal (xx33-xxx Part Number Configuration)

Lip seal kits come with one each: (A) shaft seal, (B) retaining ring, and (C) spacer. The spacer is only required for units that have extensive use in the field. The spacer puts the seal in a new location down the shaft on the sealing area. If using spacer, install the metal spacer between the shaft seal and the retaining ring (A maximum of two spacers can safely be used before the shaft must be replaced).

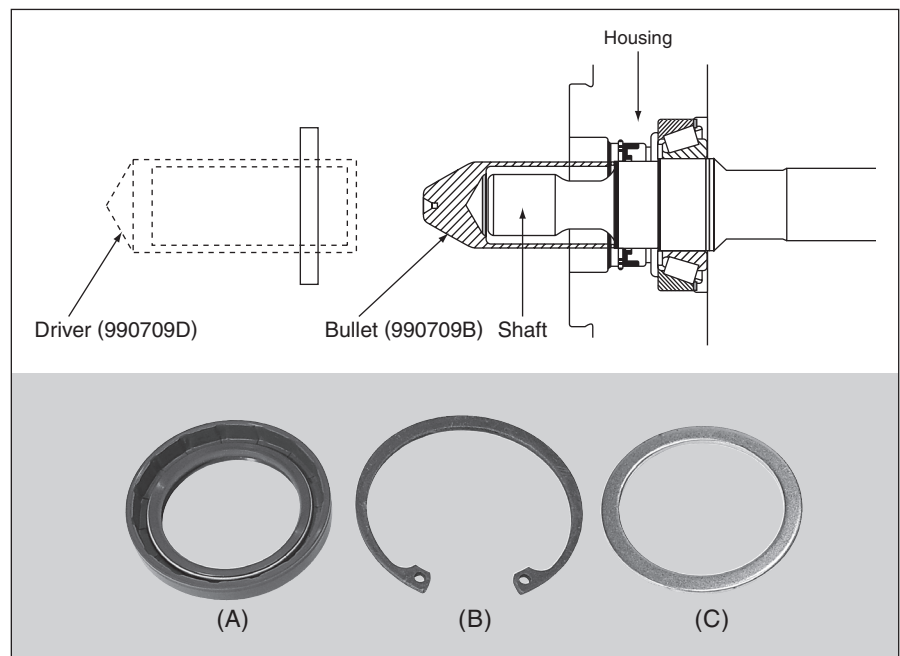

Inspect that the shaft sealing surface and housing seal bore are clean and free of all dirt and debris to ensure avoiding introduction of contaminants into unit.

1. Grease the inside surface of the shaft seal that will come in contact with the shaft.
2. Bullet and drive shaft chamfer must align with each other leaving no gap between the bullet and shaft. Bullet should pilot on shaft diameter so bullet cannot shift side to side, allowing step between bullet and shaft seal diameter.
3. Press the new, greased shaft seal over the shaft bullet; the closed face of the shaft seal needs to face the closed end of the bullet.
4. With the shaft seal on the bullet, insert bullet over drive shaft and into the seal pocket. Take care to ensure seal is properly aligned with housing bore while pressing seal into pocket to minimize the chance of damaging seal.
5. Use the driver and a mallet to slowly push the seal until the tool bottoms on the pilot of the flange.
6. Remove the driver and insert the retaining ring into the seal pocket. A spacer may be required whenever there is a significant groove worn into the shaft by the seal. (A maximum of two spacers can be used safely before the shaft must be replaced), place metal spacer between the shaft seal and the retaining ring.
7. Using the driver and a mallet, drive the seal, spacer (if required), and retaining ring in until the retaining ring snaps into place in the groove.